

*Quick & Quantitative*

# VTURN Q200

- *Two or three milling turrets with Y-axis (T2Y2 or T3Y3)*
- *Turning center with 32 (T2Y2) or 48 live tools (T3Y3)*
- *Twin spindles with belt driven motor (T2Y2) or built-in motor (T3Y3)*
- *Bar capacity 66 mm (8" chuck)*
- *Built-in unmanned automation*



# Vturn - Q200T2Y2

## Quick Production by Double Turrets

- Offering sufficient 32 tools for both OP-10 and OP-20 machining applications at quicker tool exchange compared as multi-tasking lathes with ATC.
- Used as traveling steady rest, work rest or tailstock for more flexible applications.
- Turning slender shafts or drilling/tapping the symmetric holes with upper turret simultaneously ("balanced cutting")

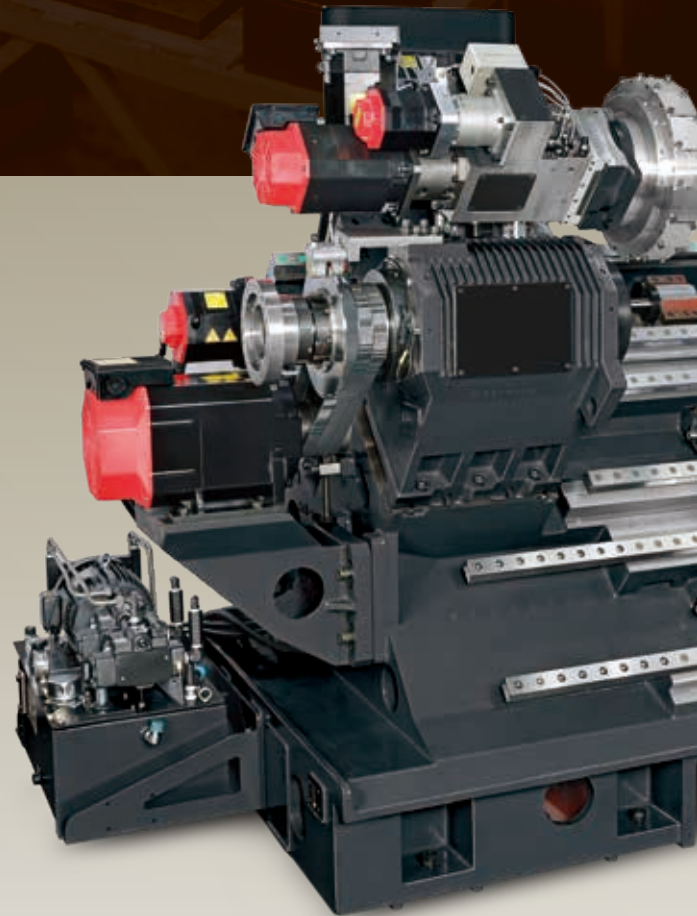

## 15 KW (S2 30 min) Spindle x2

- Shortened belt length
- 8" chuck / 4000 rpm
- Bar capacity: 66 mm (2.5")
- Spindle output 136 Nm (S2 30 min.)
- Part exchange time: 14 sec. (2500 rpm)
- Opt. built in spindle available

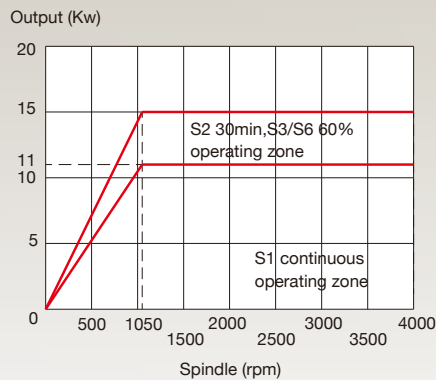
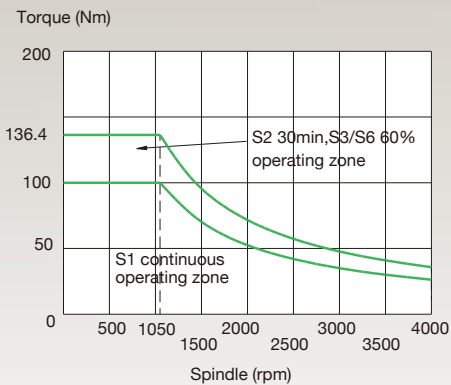

Fanuc  $\alpha$ 11 12



## BMT-55 Milling Turret x2

- Y axis travel: 45 mm (both turrets)
- 16 stations live tools
- Milling power 7.5 kW (S2 15 min.)
- Milling speed 6000 rpm
- 3 piece coupling

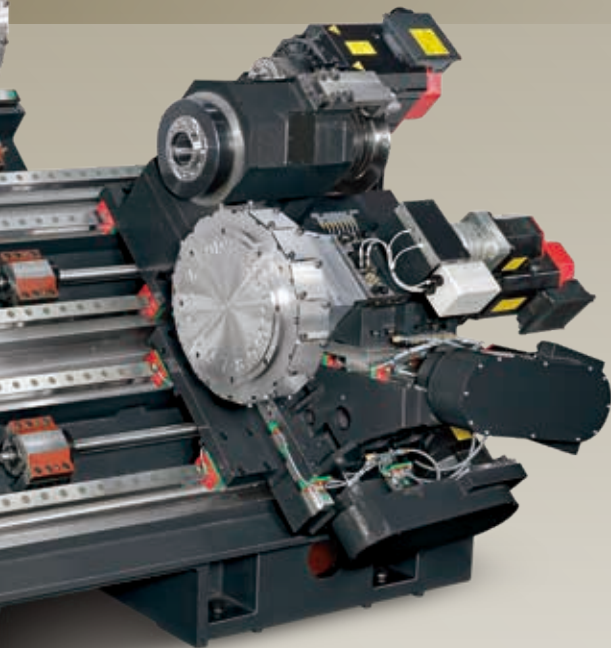
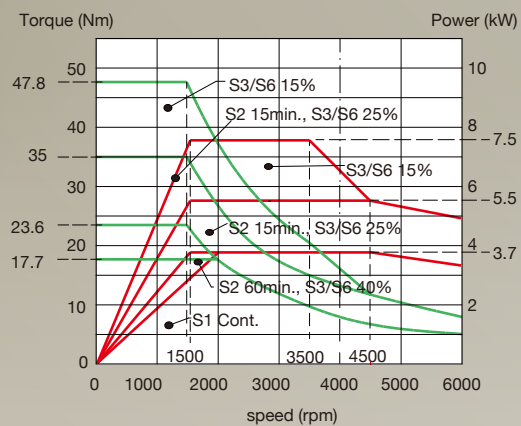

## Spindle Upgrade with Built-in Spindle x2 (opt.)

- Direct drive spindle (DDS) with built in motor 15 KW (S2 30 min)
- 8" chuck / 5000 rpm
- Bar capacity: 66 mm (2.5")
- Spindle output: 224 Nm (S2 30 min.)
- Part exchange time: 12 sec. (2500 rpm)
- Good for contour milling

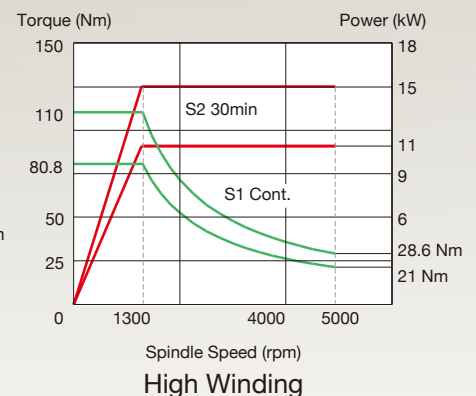
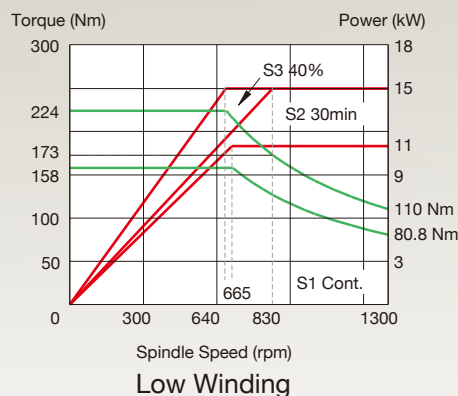

Fanuc Bil 170S

# Vturn - Q200T3Y3

## Quick Production by Innovative 3<sup>rd</sup> Turret!

- 3<sup>rd</sup> Turret facilitates additional 16 tools.
- Minimizing the cutting time difference between OP-10 and OP-20 to balance cutting tempo
- Twin spindles keep running thanks to extra turret.
- Built-in DDS spindle good for contour milling

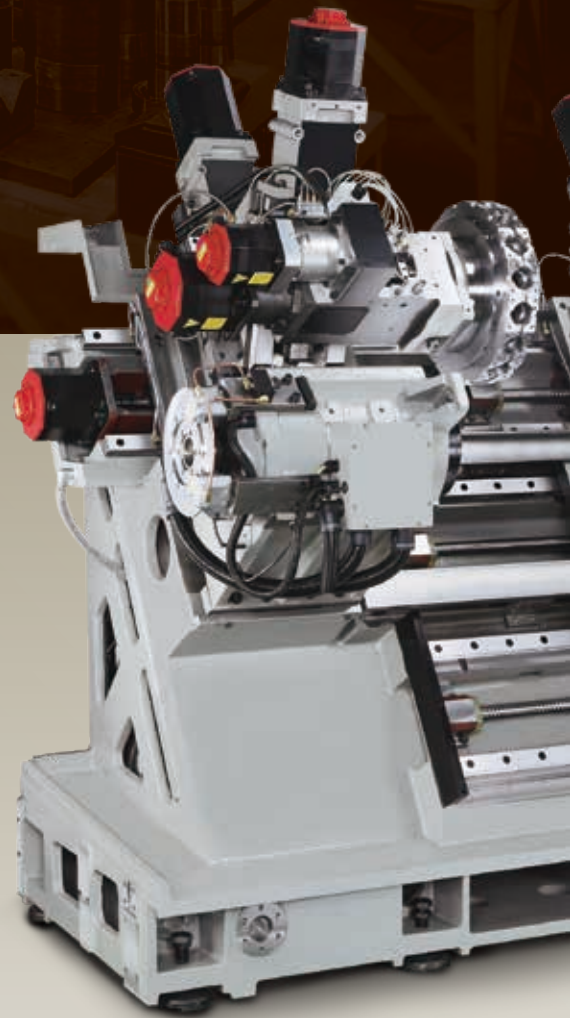

## 15 KW (S2 30 min) Spindle x2

- Direct drive spindle (DDS) with built-in motor
- 8" chuck / 5000 rpm
- Bar capacity: 66 mm (2.5")
- Spindle output 224 Nm (S2-30 min.)
- Part exchange time: 12 sec. (2500 rpm)
- Good for contour milling

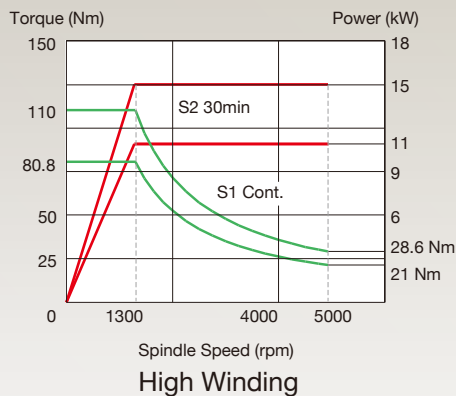
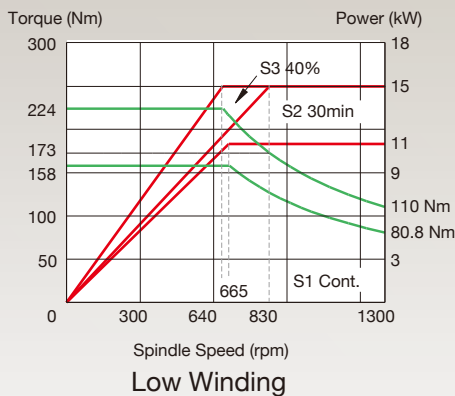

Fanuc Bil 170S

# BMT-55 Milling Turret x3

- Y-axis travel: ±45 mm (both turrets)
- 16 stations live tools
- Milling power 18 Nm / 5.5 kW (S1-cont.)
- Milling speed 6000 rpm
- 3-piece coupling

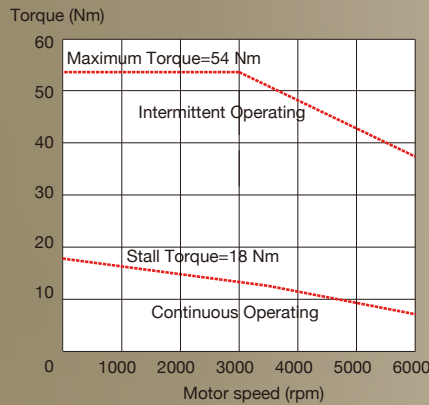

Fanuc Q22/6000is

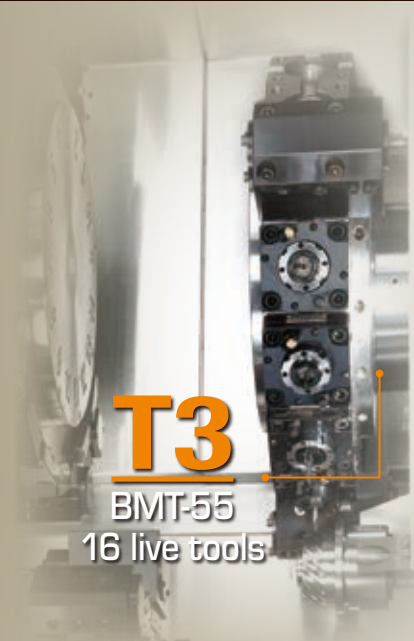

**T3**  
BMT-55  
16 live tools

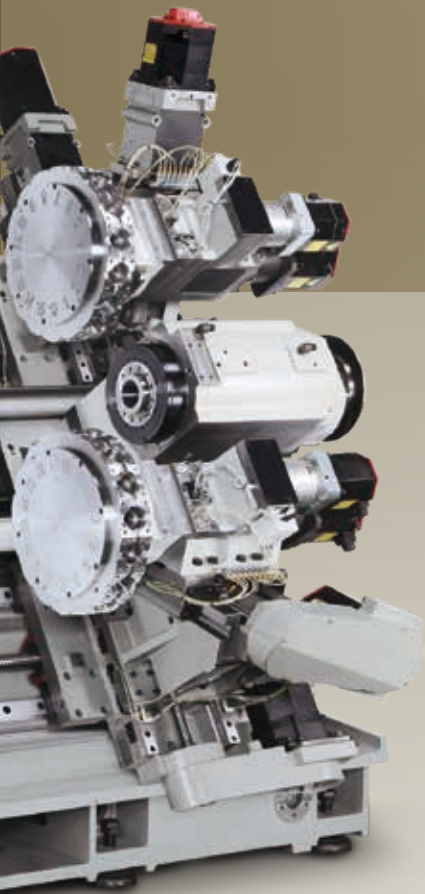

## Belt vs. Built-in spindle (tested on Aluminum part)

Belt-driven spindle

Built-in spindle



## Opt. 25 KW (S2-30 min) Spindle x2

- DDS with built-in motor
- Spindle output 323 Nm (S3-15%)

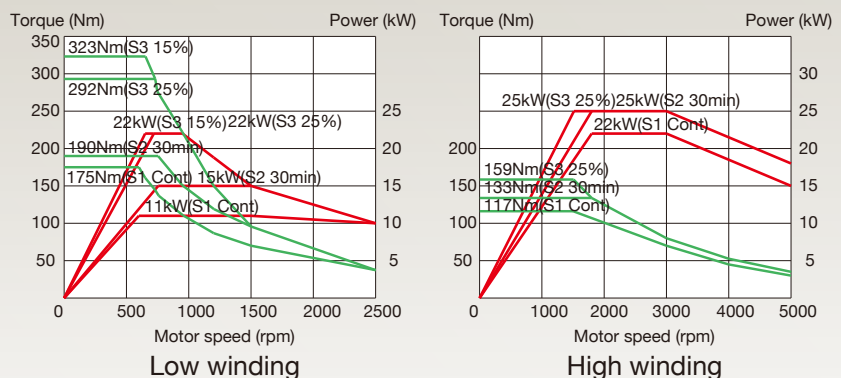

Fanuc Bil 170S motor driver upgrade

# Victor Taichung's NC Package

With 15" LCD included as standard for 3 turret model (T3Y3), Victor Taichung's Fanuc 31i-B Plus control package displays technical information for individual turret in one screen to let the machine operation become an easy job without switching different turret system. The 3D cutting simulation can be executed in MGI (Manual Guide i) and 2D on-line cutting (moving with turret during cutting along the part profile) on both spindles can be done simultaneously.

In case the 3rd turret is not required to complete the machining processes, the 10.4" monitor is able to include technical information and the controller is replaced by Fanuc Oi-TF Plus

control (T2Y2) to lower the investment costs.

Fanuc "air bag" function (DTRQ: Unexpected Disturbance Torque detection) has been integrated into NC package to minimize damages caused by faulty operation.

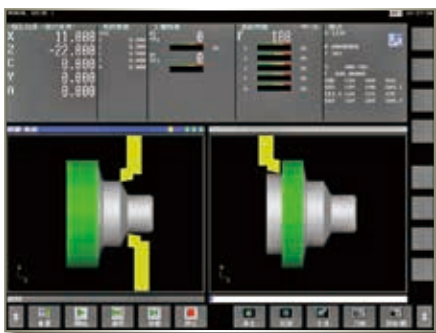

Cutting Simulation in MGI (3D)



3 turret system in one screen



Tool offset setting & display



Cutting paths on 2 parts in MGI

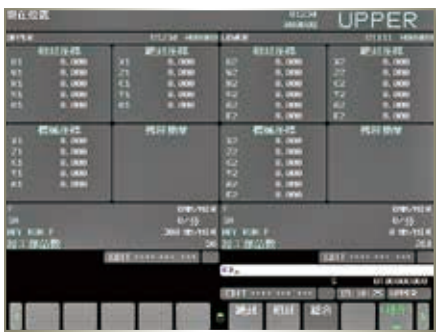

2 turret system in one screen

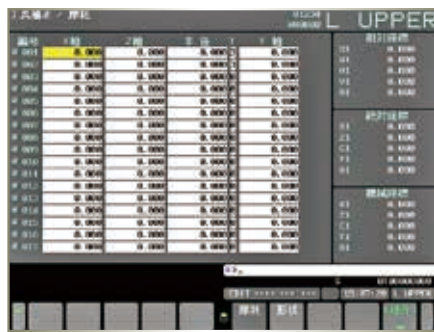

Tool offset setting & display 10.4"



Cutting paths on single part in MGI



# VICTOR's FANUC Oi-TF Plus/31i-B Plus Control SPECIFICATIONS

## STANDARD:

ITEM	SPECIFICATION	DESCRIPTION
<b>Control System:</b>		
1	Control model	Fanuc 31i-B Plus 3-path Fanuc Oi-TF Plus 2-path
2	Visual display unit	Fanuc 31i-B Plus 15" color LCD Fanuc Oi-TF Plus 10.4" color LCD
3	Keyboard unit	Separate type MDI unit (standard keys)
4	Unexpected disturbance torque detection	Std.

## Axes and Spindle control:

1	Max. Controlled Axes	20 (for 31i-B Plus), 11 (for Oi-TF Plus)
2	Simultaneously controlled axes	4 (L-Upper X1, Z1, C1 Y1, A1) + 5 (Lower X2, Z2, C2, Y2, A2, E2) + 4 (R-Upper X3, Z3, C3 Y3, A3) *Oi-TF Plus only supports two turrets
3	Spindles	2
4	Synchronous axes	Std. (twin spindles)

## Input command:

1	Least input increment	X, Z, Y, E: 0.001mm/0.0001 inch.
2	Least command increment	X: 0.0005mm, Z/Y/E: 0.001mm, C: 0.001deg.
3	Maximum programmable dimension	± 999999.999mm/ ± 39370.0767inch ± 999999.999deg
4	Absolute / Incremental programming	X,Z,C,Y,E (absolute only for E) / U,W,H,V
5	Decimal input	Std.
6	Program code	EIA / ISO automatic recognition
7	Program storage memory	Back up by battery
8	Inch / Metric conversion	G20 / G21
9	Programmable date input	G10

## Feed functions:

1	Cutting feed (when AI contouring control is not executed)	X, Z, Y, E: 1-4800mm/min (0.01-188inch/min) C: 1-4800deg/min G: 0.01-4800.0000min/rev. (0.000001-50.000000inch/rev)
2	Dwell	G04
3	Feed per minute/ rev.	G98 / G99
4	Thread cutting	G32
5	Thread cutting retract	Std.
6	Continuous thread cutting	Std.
7	Handle feed	Manual pulse generator (MPG) 0.001/0.01/0.1mm (per pulse)
8	Automatic acceleration/deceleration	Std.
9	Linear acc/deceleration after cutting feed interpolation	Std.
10	Rapid feed override	F0, 25%, 50%, 100%
11	Cutting feedrate override	0-150% (each 10%)
12	AI contouring control (40 blocks/path)	G5.1 (opt. for Oi-TF Plus)

## Program memory:

1	Part program storage length	2MB (5120m, OiTF Plus), 4MB (31iB Plus)
2	Part program editing	Delete, insert, change
3	Program number search	Std.
4	Sequence number search	Std.
5	Address number search	Std.
6	No. of registered programs	1000 (in total)
7	Multiple program simultaneous editing	Std.
8	DNC through memory card	Std. (excl. memory card)
9	Extended part memory editing	Std.

## Programming support:

1	Circular interpolation	Std.
2	Direct drawing dimension programming	Std.
3	Canned cycles	Std.
4	Multiple repetitive canned cycles	Std.(G70-G76)
5	Multiple repetitive canned cycles II	Std.(G70-G76 TYPE II)
6	Synchronous control	Std. (for C-axis)
7	Sub programs	Std.
8	Balance cut	G68-G69
9	Custom macro	Std.
10	Addition to custom macro common variables	Std.
11	Manual Guide i	Std.

## Setting and Display:

1	Status Display	Std.
2	Clock Function	Std.
3	Current Position Display	Std.
4	Program Display	Program name 32 characters
5	Parameter Setting and Display	Std.
6	Self Diagnosis Function	Std.
7	Alarm Display	Std.
8	Alarm History Display	60
9	Operation History Display	Std.
10	Help Function	Std.
11	Run Hour and Parts Count Display	Std.
12	Actual Cutting Feedrate Display	Std.
13	Display Spindle Speed and T Code At All Screens	Std.
14	Dynamic Graphic Display	Std.(Available in MGI by another function)
15	Servo Setting Screen	Std.
16	Display of Hardware and Software Configuration	Std.
17	Multi-Language Display	Std.
18	Data Protection Key	Std.
19	Erase CRT Screen Display	Std.
20	Spindle Setting Screen	Std.

## Data interface:

1	Ethernet (10/100BaseT)	Std.
2	PCMCIA port	Std. (excl. memory card)
3	RS-232-C	Std.

## CONTROL OPTIONS:

	Oi-TF Plus	31i-B Plus
1 Helical interpolation	<input type="checkbox"/>	<input type="checkbox"/>
2 Circular thread cutting (G35)	N.A.	<input type="checkbox"/>
3 3-D coordinate system conversion	N.A.	<input type="checkbox"/>
4 Data server (with PCB and ATA card)	<input type="checkbox"/>	<input type="checkbox"/>
5 Part Program Storage Length 8Mbyte (in total) Incl. Number of registered program 4000 (in total)	N.A.	<input type="checkbox"/>
6 AI contouring control I (40 blocks/path)	<input type="checkbox"/>	Std.
7 AI contour control II (G5.1 Q1) (200 blocks/path)	<input type="checkbox"/>	<input type="checkbox"/>
8 AICC II High-speed processing (400 blocks/path)	<input type="checkbox"/>	<input type="checkbox"/>
9 AICC II Look-ahead blocks expansion (1000 blocks/path)	N.A.	<input type="checkbox"/>
10 Optional block skip 2-9	<input type="checkbox"/>	<input type="checkbox"/>
11 Polygon turning	<input type="checkbox"/>	<input type="checkbox"/>
12 Manual handle feed 2 (2nd MPG)	<input type="checkbox"/>	<input type="checkbox"/>
13 Profibus	<input type="checkbox"/>	<input type="checkbox"/>
14 DeviceNet	<input type="checkbox"/>	<input type="checkbox"/>



# Standard and Options

## Ergonomic design for easy & safe operation

- **Enclosed guarding** with the **high outlet chip conveyor** fitted into the machine bed ensures no access to the machine during operation and no coolant leakages.
- **Front removed coolant tank** with **High pressure coolants** by Grundfos® pump SPK4-8 (or MTH4-4/4) improves the machining quality on part surface. **Oil skimmer** is installed on coolant tank to separate the oil layer from coolants.
- **Rotary control box** with **front mounted hydraulic gauges** facilitate the easy adjustment and operation.
- **Spindle oil cooler** for twin DDS spindles. (opt. for T2Y2).

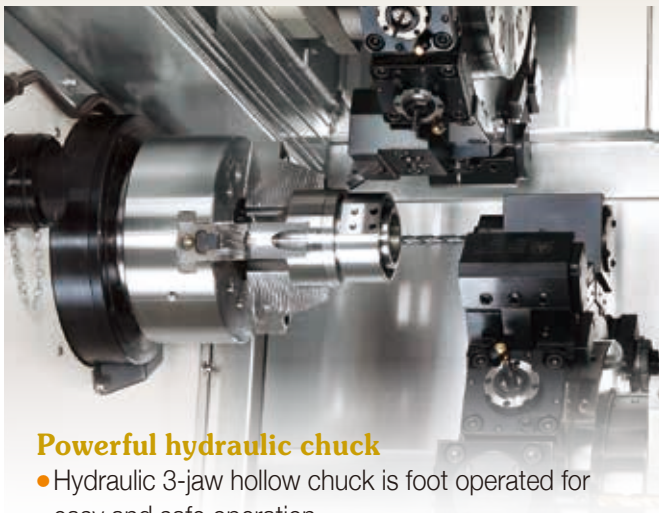

## Powerful hydraulic chuck

- Hydraulic 3-jaw hollow chuck is foot operated for easy and safe operation.

## Victor's lubrication pump

- High Quality lube pump (4 liters) ensures long service life for the machine.



## Tool Presetter (Renishaw® Tool-Eye)

The detachable manual tool presetter allows more space within the machining area, and measures the tool lengths and diameters automatically. Automatic tool presetter is used on Q200T2Y2 for calibrating tools by programming.



## Robotic Part Catcher and Part Collector (opt.)

By linking the machine to either a bar feeder or work feeding system, a robotic parts catcher then collects the finished part removing it from the machine, for either manual collection or by a part receiver to form an unmanned machining line.



# Machining Examples

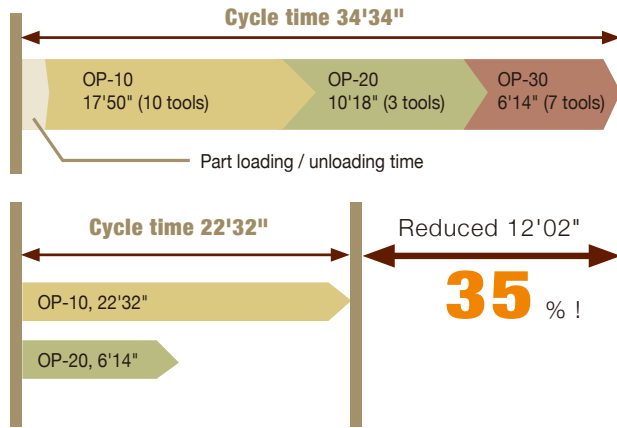
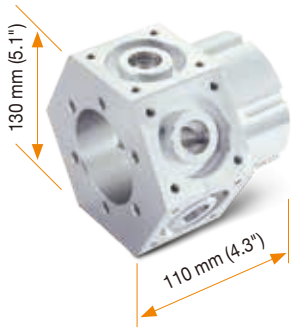

Vturn-A20YS  
(2 spindles, 1 turret)



Vturn-Q200T3Y3

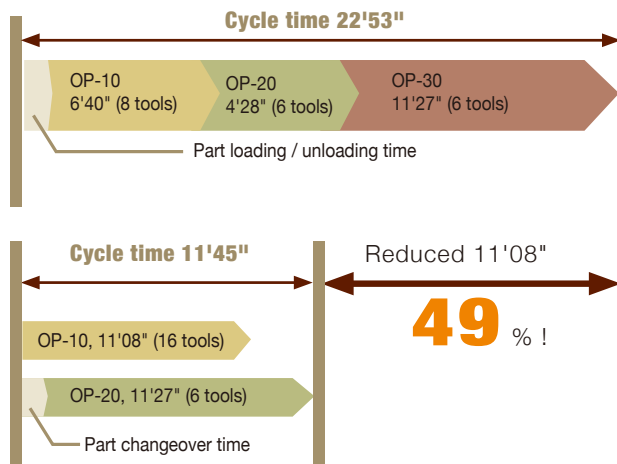

2 x Vturn-A20(YS)  
(1 spindle, 1 turret)



Vturn-Q200T3Y3

## BMT-55 Tool Holders (Optional)

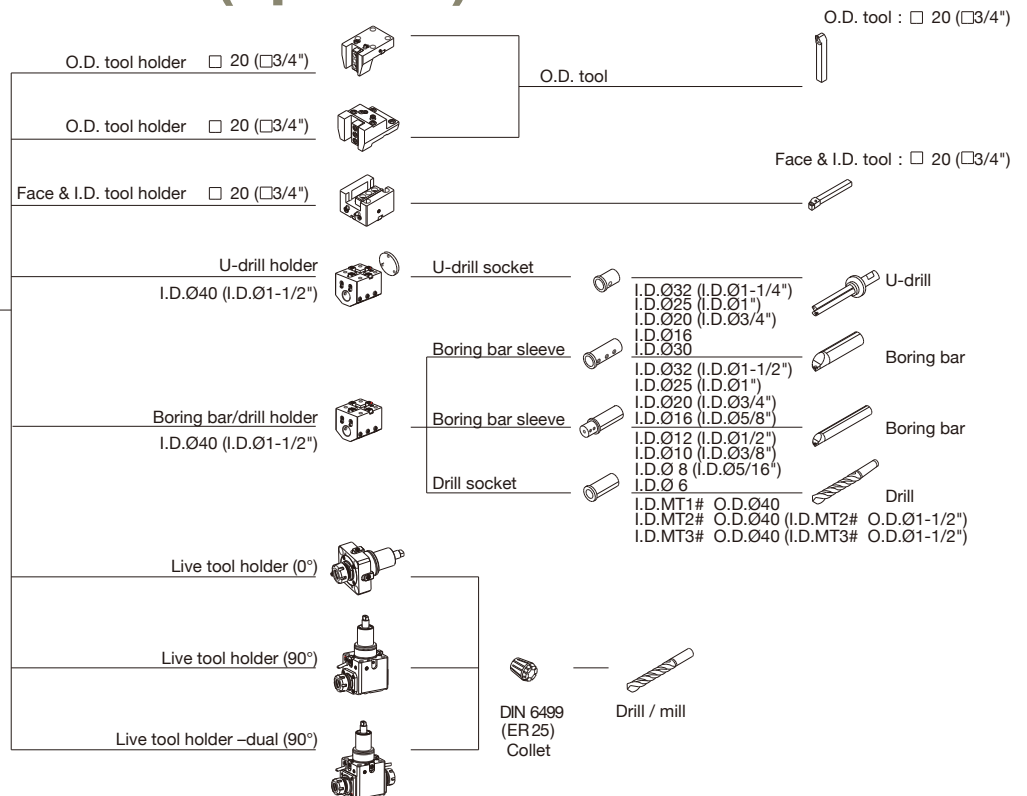
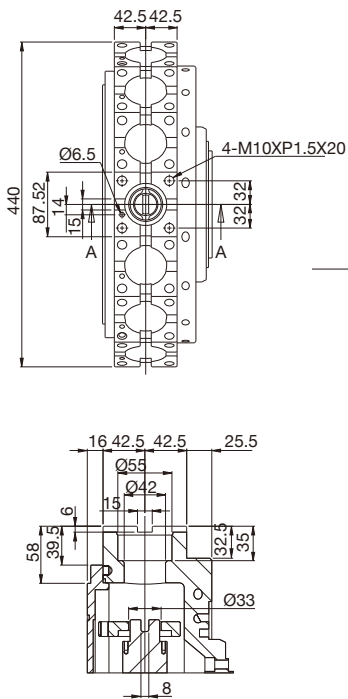

BMT-55 interface





# Machine Specification

Items	Unit	Vturn-Q200T2Y2	Vturn-Q200T3Y3	
Capacity	Swing over bed	mm	500	330
	Between centers	mm	850	850
	Max. turning dia.	mm	308	248
	Std. Turning dia.	mm	225.5	248
	Bar capacity	mm	66	66
Axis travel	Max. part dia. from 1 <sup>st</sup> spindle to 2 <sup>nd</sup> spindle	mm	280	248
	X1/X2/X3 axis travel	mm	210 (154+56)	180 (124+56)
	Z1/Z2/Z3 axis travel	mm	600	Z1/Z3: 230, Z2: 600
	E axis travel (right spindle)	mm	600	600
	Y1/Y2/Y3 axis travel	mm	± 45 (90)	± 45 (90)
	Rapid feedrate	m/min	X1/X2: 24 Z1/Z2: 30 Y1/Y2: 10, E: 24	X1/X2/X3: 24 Z1/Z2/Z3: 36 Y1/Y2/Y3: 12, E: 24
	Feed servo motor	kW	X1/X2: 3, Z1/Z2: 3 Y1/Y2: 3, E: 2.7	X1/X2/X3: 4, Z1/Z2/Z3: 3 Y1/Y2/Y3: 3, E: 3
	JOG feedrate	mm/min	X/Z=0~1260	X/Z=0~1260
	Ballscrew dia. x pitch	mm	X1/X2: 25 x P6 Z1/Z2/E: 40 x P8 Y1/Y2: 25 x P6	X1/X2/X3: 32 x P10 Z1/Z2/Z3/E: 40 x P12 Y1/Y2/Y3: 32 x P8
	Linear guideway width	mm	35 / 35 / 45	35 / boxway / 45
Left spindle	Max. spindle speed	rpm	4000 (opt. 5000 built-in)	5000
	Spindle nose (chuck)	inch	A2-6 (8")	A2-6 (8")
	Spindle bore	mm	76	76
	Spindle motor	kW	11/15 (opt. 22/25)	11/15 (opt. 22/25)
	Bearing inside dia.	mm	120	110
Right spindle	Max. spindle speed	rpm	4000 (opt. 5000 built-in)	5000
	Spindle nose (chuck)	inch	A2-6 (8")	A2-6 (8")
	Spindle bore	mm	76	76
	Spindle motor	kW	11/15 (opt. 22/25)	11/15 (opt. 22/25)
	Bearing inside dia.	mm	120	110
Turret	No. of tools	no.	T1/T2: 16	T1/T2/T3: 16
	No. of live tools	no.	16	16
	Tool shank size	mm	20	20
	Max. boring bar dia.	mm	40 (BMT-55)	40 (BMT-55)
	Exchange time (incl. turret disk up & down)	mm	1.0 (Adjacent) 1.3 (opposite)	1.0 (Adjacent) 1.3 (opposite)
	Milling speed	rpm	6000	6000
	Milling motor (cont./30 min)	kW	3.7 / 7.5	4.5
Coolant	Tank capacity	L.	330	420
Controller	FANUC		Oi-TF Plus (10.4")	31i-B Plus (15")
Machine	Power requirement	kVA	49	58
	Dimension (L x W x H)	mm	4561 x 2410 x 2400	4803 x 2335 x 2410
	Net weight	kg	9500	11200

\*Machine and controller specifications are subject to change without notice

\*\*Available with CE / UKCA / TS / GB certificates

## Standard accessories

- Hydraulic chuck with soft jaws
- Chip conveyor
- Hand wheel (Remote MPG)
- Coolant flush on Z-axis cover
- 3 step warning light
- Tool presetter (Tool-eyes, detachable for T3Y3, automatic for T2Y2)
- Oil skimmer
- Fanuc e-book (CD)

## Optional accessories

- Kitagawa® power chuck
- Robotic part catcher
- Part receiver for part catcher.
- Air conditioner for electrical cabinet (Panel cooler)
- Bar feeder interface
- Air blow
- Oil mist collector
- Hard jaws
- Auto door
- Steady rest for lower turret
- BMT-55 tool holders
- Fanuc manuals
- Handy air gun



**TAIWAN**  
<http://www.victortaichung.com>  
 E-mail :info@mail.or.com.tw  
 Victor Taichung Machinery Works Co., Ltd.  
 No. 1, Jingke Central 2nd Rd.,  
 Nantun Dist., Taichung 40852,  
 TAIWAN, R.O.C.  
 TEL : 886-4-23592101  
 FAX : 886-4-23593389

**FRANCE**  
 Victor France  
 TEL : 33-1-64772000  
 FAX : 33-1-64772063

**GERMANY**  
 Victor GmbH  
 TEL : 49-2261-478434  
 FAX : 49-2261-478327

**SOUTH AFRICA**  
 Victor Fortune (PTY) Ltd.  
 TEL : 27-11-3923800  
 FAX : 27-11-3923899

**MALAYSIA**  
 Victor Machinery (M) SDN. BHD.  
 TEL : 60-3-56337180  
 FAX : 60-3-56337191

**THAILAND**  
 Victor CNC (Thailand) Co., Ltd.  
 TEL : 66-2-9263735  
 FAX : 66-2-9032373

**INDONESIA**  
 PT. Victor Machinery Indonesia  
 TEL : +62-21-88958504  
 FAX : +62-21-88958513

**USA**  
 Fortune International Inc.  
 TEL : 1-732-2140700  
 FAX : 1-732-2140701

**CHINA**  
 Victor Taichung Machinery (Shanghai)  
 TEL : 86-21-59768018  
 FAX : 86-21-59768009